

# EST™

## Dry Emergency Gas Scrubber Systems

Severn Trent Services' EST™ dry emergency scrubbers are engineered to meet national codes for the mitigation of hazardous gas releases from pressurized 150-pound cylinders and one-ton containers of chlorine, sulfur dioxide, ammonia and other toxic gases. Dry scrubbers are safe, user-friendly, low maintenance systems tested and proven for use in municipal and industrial applications where the potential exists for the accidental release of heavier-than-air hazardous gases.

The EST Type DES dry emergency scrubber is used to scrub the entire contents of an overfilled one-ton container at the exhaust rate of 3000 CFM. For smaller containers like 150-pound cylinders, the EST Type DSH dry scrub house system will exhaust and clean air from the contaminated room at the rate of 400 CFM.

Both the EST Type DES and DSH are fabricated from industrial grade Fiberglass-Reinforced Plastic (FRP) to provide internal as well as external corrosion resistance over many years of operation and exposure to harsh weather conditions. In addition, dry chlorine scrubbers do not require liquid chemical leak containment or double wall vessel construction and operate at sub-zero temperatures without the use of heaters.



Type DES



Type DSH

### Features and Benefits:

- No chemical maintenance
- New and used media is non-hazardous
- One moving part - fan
- No chemical pumps
- Chemical leak containment is not required
- No heaters required in cold climates
- Safe
- User-friendly
- Dependable operation
- Tested and certified
- Low cost of ownership



**Dry Emergency Scrubber for One-Ton Containers**

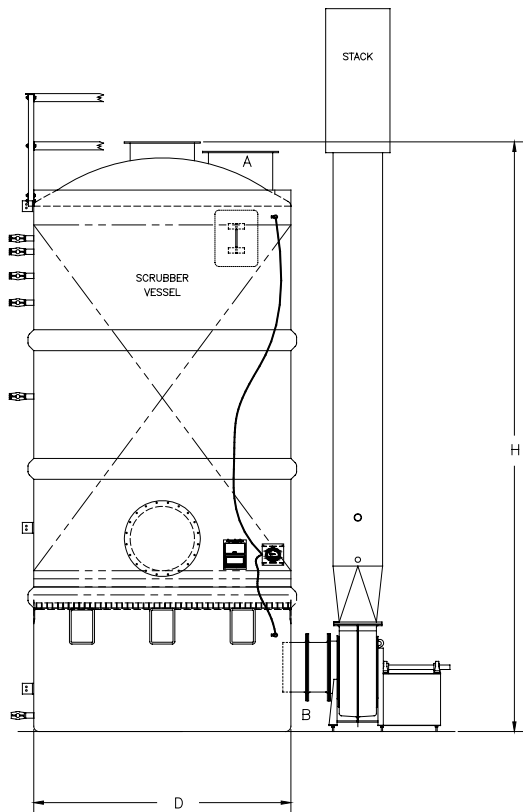

The EST™ Type DES dry emergency scrubber system is designed to scrub a leak from an overfilled one-ton portable tank in accordance with the Uniform Fire Code worst-case release of hazardous gas through a fusible plug. The Type DES 3000 has a room exhaust rate of 3000 cubic feet per minute. The leak from a one-ton portable chlorine container could reach an initial 2400 CFM peak rate. The 3000 CFM scrubber exhaust rate assures a negative pressure on the room, resulting in fugitive gas containment.

When sulfur dioxide is present and needs to be scrubbed either alone or in conjunction with chlorine, the bi-functional Type “PHD” chemical media will be used. The “STS” media is considered when chlorine is the lone contaminant gas present.

Larger multi-ton scrubber applications for 17-ton trailers, 55-ton stationary tanks and 90-ton railcars are more economically serviced by EST™ wet scrubber systems found in Bulletin 300 entitled “Emergency Scrubber Systems”.

For 150-pound cylinders normally stored in small rooms or FRP shelters, please consider the EST™ Type DSH Dry Scrub House detailed on the next page.

Size	Dimensions				WT LBS	Horsepower
	D	H	A (INLET)	B (OUTLET)		
3000	8'	18'-0"	18"	18"	3000	20

- Notes:
1. Size 3000 is offered with both “STS” and “PHD” media.
  2. The model size number indicates the scrubber exhaust rate in CFM.
  3. Weight is based on an empty single fan system.

**Available upon request:**

- CAD Drawings
- Sample specifications
- Media MSDS sheets
- Performance test code certifications
- On-site room audits
- Custom designs

Dry Scrub House for 150-Pound Cylinders

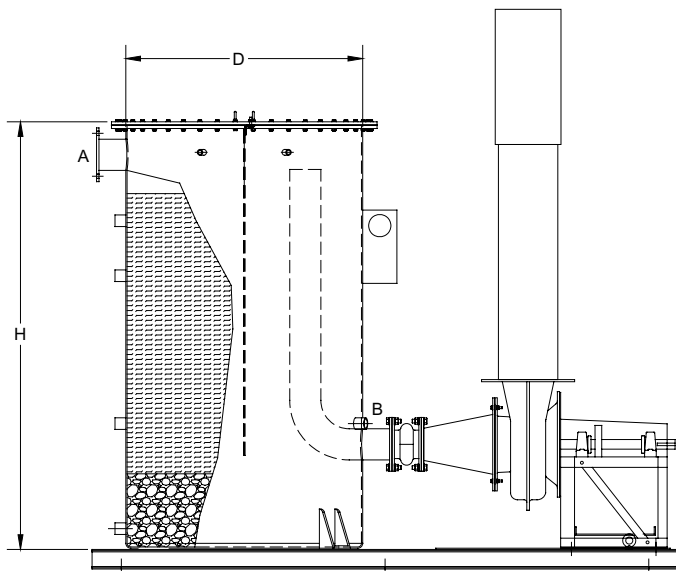

The EST™ Type DSH dry scrub house is a dry emergency scrubber system designed to scrub a leak from an overfilled 150-pound cylinder of hazardous gas at a leak rate in accordance with Uniform Fire Code requirements while constantly maintaining a negative pressure on the cylinder storage room. The EST Type DSH offers all the benefits of the larger Type DES with the additional advantage of low profile operation. The Type DSH 400 is designed to treat a chlorine release at a room exhaust rate of 400 cubic feet per minute. The fusible plug leak from a 150-pound chlorine cylinder could reach an initial 115 CFM peak rate. The 400 CFM scrubber exhaust rate assures a negative pressure on the room and fugitive gas containment.

The bi-functional chlorine/sulfur dioxide scrubbing media Type “PHD” or the chlorine specific “STS” media will be used depending on the gases needed to be scrubbed.

Size	Dimensions				WT LBS	Horsepower
	D	H	A (INLET)	B (OUTLET)		
400	4'	7'-4"	6"	6"	900	2

Notes:

1. Size 400 is offered with both “STS” and “PHD” media.
2. The model size number indicates the scrubber exhaust rate in CFM.
3. Weight is based on an empty single fan system without skid.

Available upon request:

- CAD Drawings
- Sample specifications
- Media MSDS sheets
- Performance test code certifications
- On-site room audits
- Custom designs

# Ask for other EST™ products available from Severn Trent Services



## Solids Conveyors

- Transport solids with gases or liquids
- Mix solids and liquids
- Handle slurries

575.0001



## Wet Emergency Scrubber Systems

- Protection against accidental gas releases
- Scrub Chlorine, Ammonia and Sulfur Dioxide

575.0005



## Desuperheaters

- Desuperheating steam
- Gas cooling
- Waste heat recovery

575.0035



## Heaters

- Inline steam heating
- Tank steam heating
- Direct contact heaters
- Shell & tube heaters

575.0020



## Exhausters & Compressors

- Liquid jet exhausters handle gases with liquid motive sources
- Gas jet compressors handle gases with gas motive sources

575.0025



## Vacuum Systems

- Handle gases under vacuum using steam
- Multi-stage ejectors
- Non-condensing and condensing systems
- Shell & tube and direct contact condensers

575.0030



## Eductors, Syphons & Mixers

- Liquid pumping, heating and mixing applications
- Liquid and gas motive source
- Specialized designs for erosive or corrosive applications

575.0015



## Wet Scrubber Systems

- Ejector venturi scrubbers
- Packed tower scrubbers
- High energy scrubbers
- Packaged systems

575.0040



## Wet Odor Scrubber Systems

- Treat malodorous gases
- Municipal and Industrial wastewater treatment plants

575.0045

## Other related products from Severn Trent Services



## Gas Shut-off System

- SafeTC
- Rapid, automatic closure of chlorine container valves

140.0005



## Gas Feeders

- Capital Controls®
- Vacuum gas feeders
- Pressure gas feeders
- Automatic gas control valves
- Vaporizers
- Custom systems

105.0055



## Gas Detectors

- Capital Controls®
- Chlorine and sulfur dioxide gas leak detection

325.0001

### Severn Trent Services

3000 Advance Lane

Colmar, PA 18915

Tel 215 997 4000

Fax 215 997 4062

marketing@severntrentservices.com

575.0301.1 09/06