

---

---

Instruction Manual -  
ADVANCE® Model 480  
Remote Meter Panel

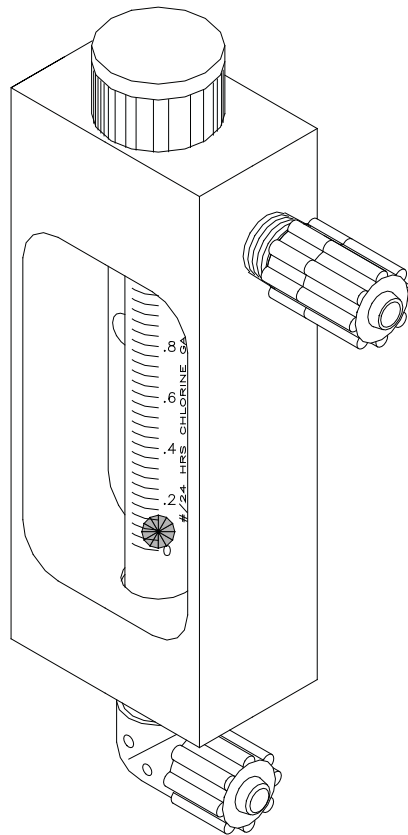

---

---

These instructions describe the installation, operation and maintenance of the subject equipment. Failure to strictly follow these instructions can lead to equipment rupture that may cause significant property damage, severe personal injury and even death. If you do not understand these instructions, please call De Nora Water Technologies for clarification before commencing any work at +1 215-997-4000 and ask for a Field Service Manager. De Nora Water Technologies, Inc. reserves the rights to make engineering refinements that may not be described herein. It is the responsibility of the installer to contact De Nora Water Technologies, Inc. for information that cannot be answered specifically by these instructions.

**Any customer request to alter or reduce the design safeguards incorporated into De Nora Water Technologies equipment is conditioned on the customer absolving De Nora Water Technologies from any consequences of such a decision.**

De Nora Water Technologies has developed the recommended installation, operating and maintenance procedures with careful attention to safety. In addition to instruction/operating manuals, all instructions given on labels or attached tags should be followed. Regardless of these efforts, it is not possible to eliminate all hazards from the equipment or foresee every possible hazard that may occur. It is the responsibility of the installer to ensure that the recommended installation instructions are followed. It is the responsibility of the user to ensure that the recommended operating and maintenance instructions are followed. De Nora Water Technologies, Inc. cannot be responsible deviations from the recommended instructions that may result in a hazardous or unsafe condition.

De Nora Water Technologies, Inc. cannot be responsible for the overall system design of which our equipment may be an integral part of or any unauthorized modifications to the equipment made by any party other than De Nora Water Technologies, Inc.

De Nora Water Technologies, Inc. takes all reasonable precautions in packaging the equipment to prevent shipping damage. Carefully inspect each item and report damages immediately to the shipping agent involved for equipment shipped "F.O.B. Colmar" or to De Nora Water Technologies for equipment shipped "F.O.B Jobsite". Do not install damaged equipment.

**De Nora Water Technologies, COLMAR OPERATIONS  
COLMAR, PENNSYLVANIA, USA  
IS ISO 9001: 2008 CERTIFIED**

---

---

# Table of Contents

<b>1</b>	<b>INTRODUCTION</b> .....	<b>4</b>
	1.1 General .....	4
	1.2 Warranty and Service.....	4
	1.3 Specifications.....	4
<b>2</b>	<b>OPERATION</b> .....	<b>5</b>
	2.1 General .....	5
	2.2 Installation.....	5
<b>3</b>	<b>START-UP</b> .....	
<b>8</b>		
<b>4</b>	<b>SERVICE</b> .....	<b>9</b>
	4.1 Cleaning the Flowmeter Assembly.....	9
	4.2 Rate Valve Cleaning .....	9
<b>5</b>	<b>TROUBLESHOOTING CHART</b> .....	<b>10</b>
	<b>FIGURES</b>	
	1 Dimensions and Mounting Hole Locations.....	6
	2 Remote Meter Panel Components.....	7

---

---

# 1 INTRODUCTION

## 1.1 General

ADVANCE® Model 480 remote meter panels are expertly engineered and carefully tested to assure years of satisfactory operation. The meter panels are constructed of the finest materials available for chlorine gas service. Proper installation and care will ensure the best operation. Please read instructions carefully and retain for future reference.

These instructions cover Model 480 Remote Meter panels only. Refer to the following for other components:

Vacuum regulator - 100.6001

Ejector - 122.6001

Automatic Switchover -100.6030

## Warranty and Service

See 005.9001 for De Nora Water Technologies equipment warranty and 005.9002 for service.

NOTE: The Model 480 Remote Meter Panel is designed to feed chlorine gas under vacuum and for use with the Model 480 chlorinator. The De Nora Water Technologies equipment warranty and service policy is null and void, as it pertains to user protection, if the Model 480 Remote Meter Panel is misapplied.

It is recommended that the Gas Dispensing System be inspected and serviced a minimum of once per year.

More frequent service periods may be required due to: 1) the type, quality and quantity of the gas being handled, 2) the complexity of the gas supply system and 3) operation procedures.

More frequent service periods are especially indicated when venting of the VR is occurring during the one year operational period. This is usually indicative of foreign debris holding the inlet valve open or destruction of the inlet valve parts caused by the gas quality not up to industry purity standards.

## Specifications

### 1.3

- 1.3.1 Flowmeter capacities: 4, 10, 25, 50 and 100 PPD (75 and 200 g/h, 0.5, 1 and 2 kg/h)
- 1.3.2 Flowmeter length 3" (76 mm)
- 1.3.3 Accuracy:  $\pm 4\%$  of maximum flowmeter capacity
- 1.3.4 Tubing connections: 3/8" inlet and outlet

---

---

## 2 OPERATION

### 2.1 General

The remote meter panel is designed to complement the ADVANCE® Model 480 vacuum regulators. When multiple chlorine gas feed points off the same vacuum regulator are required, a remote meter panel is utilized. Each remote meter panel is manually set, via the rate valve, to meter the proper amount of chlorine gas to the feed point. The combined gas feed rate from the remote meters must not exceed the total feed rate capacity of the vacuum regulator.

### 2.2 Installation

The remote meter panel must be installed in a vertical position in order to function properly.

The remote meter panel is installed in the vacuum line between the ejector and the vacuum regulator. Locate the meter panel on a vertical surface convenient for observation and operation, usually in the operator's area, with the point of chlorine injection at the desired remote location. Mount the meter panel using two (2) 1/4" mounting screws. See Figure 1. If the surface is not suitable for wood screws, choose the appropriate anchor bolts for the surface.

Black polyethylene tubing is normally used for the vacuum line. Do not kink this tubing. It may be desirable to use tubing connectors, tees or 90° elbows to provide as direct a run as possible and minimize kinking conditions. Use enough tubing length to allow movement of the vacuum regulator for servicing or cylinder change. To install the tubing connectors, proceed as follows:

- 2.2.1 Remove the bottom vacuum inlet connector nut from the remote meter panel and slip the connector nut onto the vacuum tubing coming from the vacuum regulator.
- 2.2.2 Push the tubing onto the tubing connector and tighten the connector nut HAND TIGHT.
- 2.2.3 Remove the connector nut from the vacuum outlet (top) of the remote meter and slip onto vacuum tubing going to the ejector.
- 2.2.4 Push the tubing onto the tubing connector and tighten the connector nut HAND TIGHT.

**NOTE:** There may be installations where multiple meter panels may be used from one vacuum regulator. If this occurs, the more suitable vacuum inlet may be a tee rather than a 90° elbow to simplify installation, as illustrated in Figure 2. The use of a tee will permit connection to additional meter panels.

**CAUTION:** Replacement fitting should be installed/tightened HAND TIGHT ONLY.

Routing vacuum tubing through unventilated conduit is discouraged. A minute portion of gas flowing through tubing under vacuum conditions, will slowly diffuse at a molecular level through its walls and collect in the closed conduit over an extended period of time

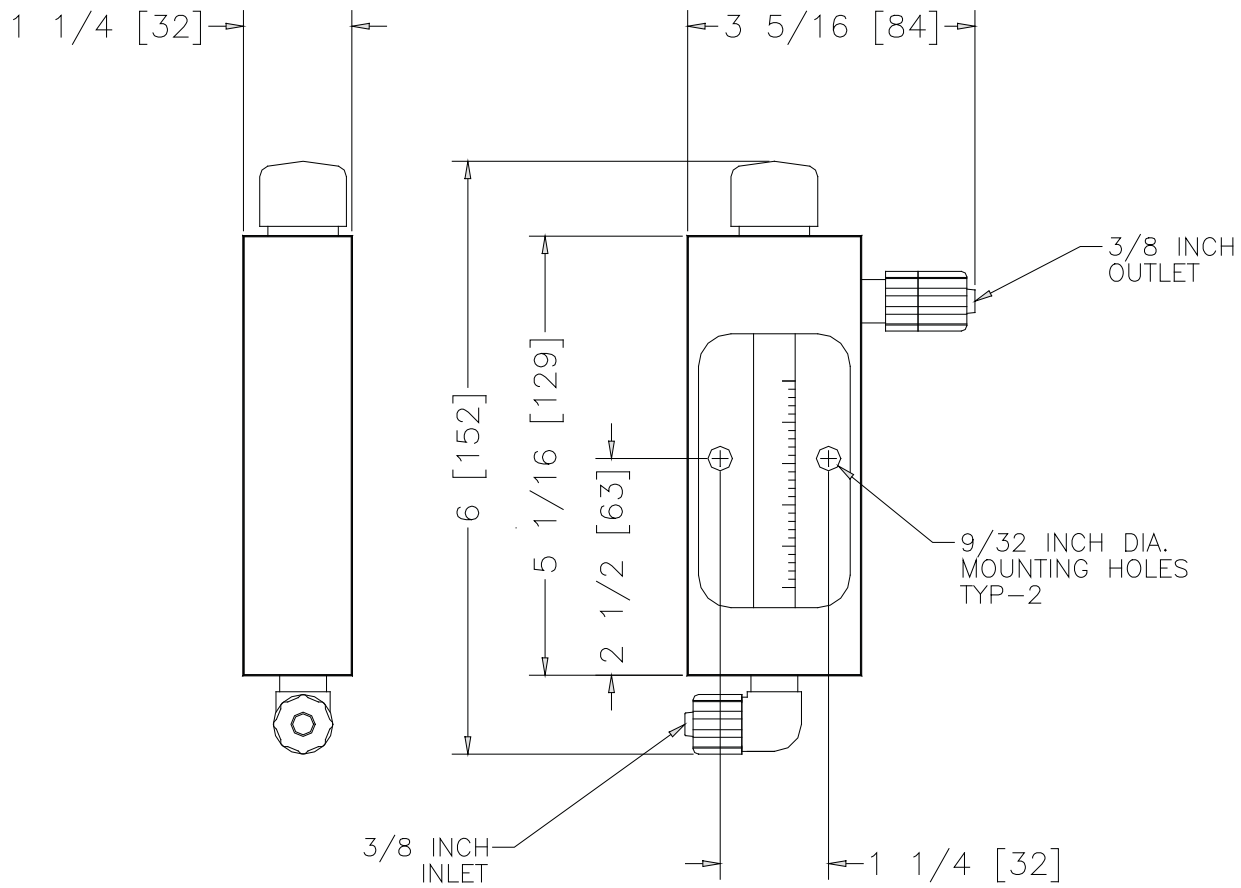

Dimensions = inches [millimeters]

Figure 1 - Dimensions and Mounting Hole Locations

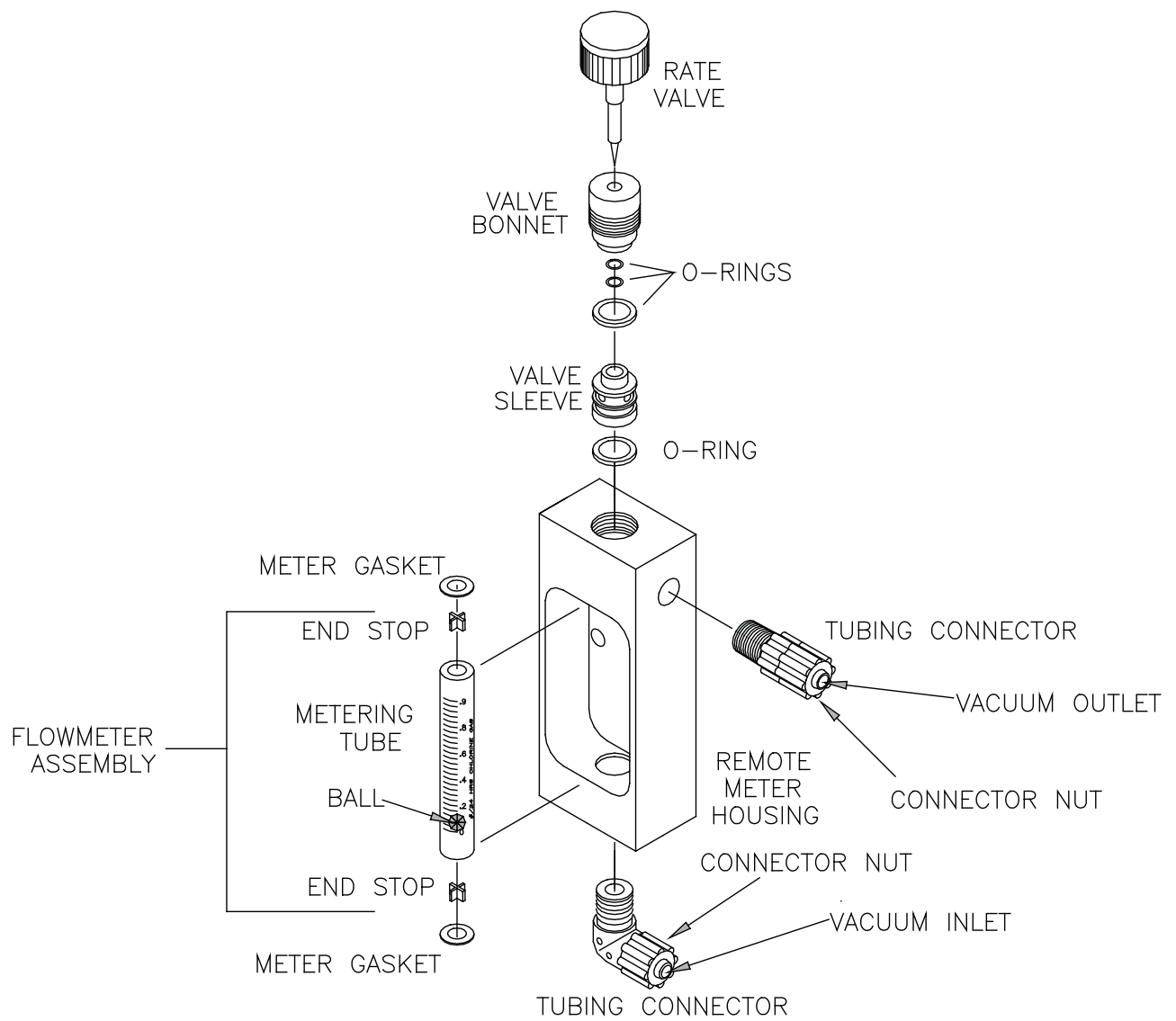

Figure 2 - Remote Meter Panel Components

---

### 3 START-UP

- 3.1 Follow the instructions provided in the vacuum regulator Instruction Manual 100.6001 for complete system start-up procedures.
- 3.2 After the system has been tested for leaks and is operating, adjust the rate valve to the desired gas flow rate. Chlorine gas flow rates in PPD (pounds per day), g/h (grams per hour), or kg/h (kilograms per hour) are on the scale. Read the flowmeter scale at the center of the ball.

**NOTE:** NEVER use the rate valve on the remote meter panel to shut off the gas supply. This valve is for adjusting flow rate while the system is in operation. If used for shutoff, this valve can be damaged. To shut off the gas, close the cylinder valve.

**NOTE:** Vacuum regulator should not have a rate valve. Rate valve should be replaced with top meter plug. See instruction manual 100.6001 and parts list 100.7001.



---

---

## 4 SERVICE

NOTE: Preventative maintenance kits for each of the assemblies are available from the factory. Each kit contains all the parts and detailed instructions that are required for complete maintenance. All o-rings and gaskets that have been disturbed during the disassembly must be replaced during reassembly in order to insure safe, trouble free operation. Failure to replace these parts could result in a shortened operation period and bodily injury.

### 4.1 Cleaning the Flowmeter Assembly

- 4.1.1 Remove the rate valve from the valve bonnet by turning counter-clockwise and pulling upward. See Figure 2
- 4.1.2 Hold the metering tube and unscrew the rate valve bonnet 3 to 4 turns. Push up on the metering tube and pull out at the bottom.
- 4.1.3 Bend a paper clip or wire and pull out the ball stops on each end of the glass tube. **DO NOT LOSE THE METERING BALL.**
- 4.1.4 Clean the inside of the glass tube with a pipe cleaner using denatured alcohol, and rinse thoroughly and dry.
- 4.1.5 Clean the metering ball using denatured alcohol and rinse thoroughly and dry.
- 4.1.6 Thoroughly dry the glass metering tube. Re-assemble the metering stops and ball.
- 4.1.7 Re-install the meter assembly by tightening the valve bonnet making sure that it is on center with the top and bottom gasket.

NOTE: The meter gaskets can usually be reused. Turn the gaskets over for best results.

### 4.2 Rate Valve Cleaning

- 4.2.1 Unscrew the rate valve plug from the valve bonnet.
- 4.2.2 Remove flowmeter assembly as described in section 4.1.
- 4.2.3 Remove the valve bonnet from the top of the remote meter housing.
- 4.2.4 Use a screw (1/4-20 thread) and screw into the valve sleeve by hand. Pull up on the screw to remove the valve sleeve. Remove the screw and save.
- 4.2.5 Clean the parts by immersing in alcohol. Rinse thoroughly, and dry with a clean cloth.
- 4.2.6 The o-rings in the valve bonnet will need replacing if scratched or bruised.

The o-ring on the outside of the valve sleeve usually will require replacing, if flattened.

- 4.2.7 Inspect the rate valve hole in the meter housing and clean with a damp cloth if necessary.

DO NOT use any sharp tools that may scratch the internal surface. Never use any solvent for cleaning the plastic, as it will deteriorate rapidly. Denatured alcohol can, however, be used successfully.

- 4.2.8 Apply a thin film of fluorolube grease to o-rings and slide the valve sleeve into the top body. Position the metering tube in the center of the gaskets and tighten the valve bonnet by hand until the metering tube cannot be turned. Refer to section 4.1
- 4.2.9 Re-install the rate valve into the valve bonnet.

## 5 TROUBLESHOOTING CHART

Since the operating performance of the remote meter panel can be effected by the vacuum regulator and ejector, also refer to the Troubleshooting Chart in the vacuum regulator instruction manual 100.6001, and the ejector instruction manual 122.6001.

CONDITION	PROBABLE CAUSE	CORRECTIVEN ACTION
1. The required gas feed rate is not achieved at start-up.	<ul style="list-style-type: none"> <li>a. Insufficient ejector vacuum due to insufficient water supply pressure for existing back pressure conditions.</li> <li>b. Leakage at vacuum line connections, vacuum regulator, and/or inlet to ejector.</li> <li>c. Vacuum line(s) crimped or kinked.</li> <li>d. Length of vacuum line(s) exceeds maximum allowable transport distance.</li> </ul>	<ul style="list-style-type: none"> <li>a. Refer to Trouble 2.</li> <li>b. Inspect each connection and re-make as necessary</li> <li>c. Replace vacuum tubing and arrange line(s) to eliminate the problem.</li> <li>d. Refer to Bulletin 121.3003.</li> </ul>
2. Flowmeter ball bounces and/or maximum gas feed rate cannot be achieved during normal operation.	<ul style="list-style-type: none"> <li>a. Rate valve dirty.</li> <li>b. Flowmeter dirty.</li> <li>c. Ejector water supply pressure fluctuating causing insufficient ejector vacuum (ball bouncing only).</li> </ul>	<ul style="list-style-type: none"> <li>a. Clean the rate valve, See Section 4.2.</li> <li>b. Clean the flowmeter. See Section 4.1.</li> <li>c. Check water supply pressure. Correct as necessary.</li> </ul>
3. Flooded metering tube	<ul style="list-style-type: none"> <li>a. Dirt on ejector check valve seat or worn seat.</li> </ul>	<ul style="list-style-type: none"> <li>a. Clean or replace ejector check valve seat. Refer to Bulletin 122.6001.</li> </ul>
4. Vacuum leaks.	<ul style="list-style-type: none"> <li>a. Rate valve O-rings worn.</li> <li>b. Tubing connectors loose.</li> </ul>	<ul style="list-style-type: none"> <li>a. Replace rate valve O-ring.</li> <li>b. Tighten tubing connectors.</li> </ul>

Design improvements may be made without notice.

Represented by:



**De Nora Water Technologies**

3000 Advance Lane Colmar, PA 18915  
 ph +1 215 997 4000 • fax +1 215 997 4062  
 web: www.denora.com  
 mail: info.dnwt@denora.com

®Registered Trademark. © 2015. All Rights Reserved